



Down to earth, technology - oriented
Focus on quality, brand name service

Add: 7/F, No. 19, Aigehao Road, Weitang town,
Xiangcheng District, Suzhou City, Jiangsu Province, China

Tel: 0086-512-67220390

Web: www.gaxiaofan.com

E-mail: tinashen@jsgaxiao.com

JIANGSU GAXIAO
ENVIRONMENTAL TECHNOLOGY CO., LTD

THE SECOND REVOLUTION OF

HVLS FAN ▶

The pioneer technical team of HVLS Fan

GX HVLS Fan

A large, industrial HVLS fan is shown in a warehouse setting. The fan is mounted on a high ceiling and is surrounded by stacks of materials. The warehouse has a high, arched metal roof structure.

JIANG SU GA XIAO
ENVIRONMENTAL TECHNOLOGY



DEVELOPMENT History

In 2000, MacroAIR HVLS company allied with Ebm-papst, Ziehl-abegg, Fasco and CMG(Regal UNK it Group), Multiwing, Torin and LauIndustries produced the first industrial fan in the whole world. This fan applied in local animal husbandry. In the next few years, the technical director left from MacroAIR, and create BigAss Fan, which is the large-scale industrial fan manufacturer.

In 2007, MacroAIR HVLS company technician built the first large-scale industrial fan with the domestic technical expert team, filled the blank of domestic industry fan market.

After years of cultivation, the market capacity has expanded year by year, coupled with inadequate protection of intellectual property rights in China and relatively low threshold for entry, resulting in a large number of competitors. Most of the competitors are in the "family workshop style", and the 'blue sea' instantly turns 'Red Sea', similar to other industrial manufacturing fields, and the industry has entered a vicious cycle of homogenization and price war.

We have tried to continue to invest in R & D technology, establish the standards of the fan industry, standardize the order of the industry, and turn vicious competition into the technical quality. However, because it is difficult to reach a consensus with some competitors, the efforts to standardize the industry have failed.

In 2017, the pioneering technical team of large-scale industrial fan, built up a trinity of technology, quality, service with top universities — JIANGSU GAXIAO ENVIRONMENTAL TECHNOLOGY CO., LTD.

On the basis of the traditional fan, our products are refined, finely polished, and the "seventh generation of industry" products of higher safety and environmental protection are introduced, and the world's original drive system — the large industrial fan of air source and the new concept commercial fan which is in line with the utility of large public occasions. According to the use, the occasion, the scene, the large industrial fan is divided into three kinds of products — the classic 'seventh generation' industrial fan, the new concept of commercial large fan, and the large industrial fan with safe and stable air source for a long time.

In 2019, we will continue to stand on the forefront, bring new and high-quality products to customers at home and abroad, and provide more high-quality services. In 2019, it will be a year of full success for Jiangsu Gaxiao, and will be a year for us to achieve a win-win situation with our customers and friends.

2000

2007

2012

2015

2017

2018

2019





Corporate Purpose

Down to earth, Technology - oriented, Focus on quality,
Brand name service



Corporate Mission

Energy saving, low carbon and environmental
protection make the world cool and refreshing.



Enterprise Vision

Integrate the resources of the industry and carry out the second
technological revolution in the industry. With trinity of technology, quality
and service to achieve "return of the king", leading the industry rational,
sustainable and high efficient development.

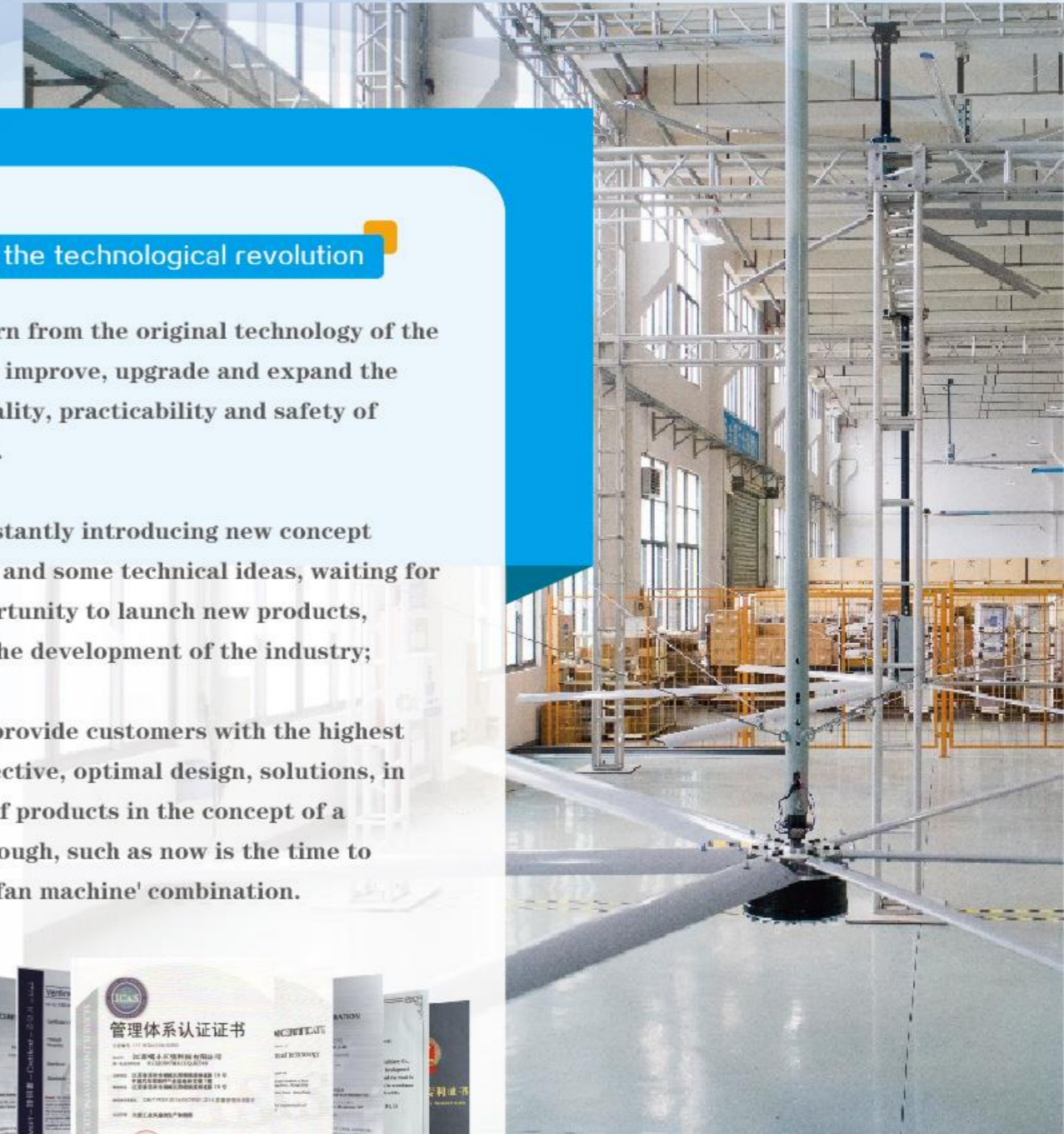

What is the technological revolution

- ◆ 1. Learn from the original technology of the industry, improve, upgrade and expand the functionality, practicability and safety of products.
- ◆ 2. Constantly introducing new concept products and some technical ideas, waiting for the opportunity to launch new products, leading the development of the industry;
- ◆ 3. To provide customers with the highest cost-effective, optimal design, solutions, in the use of products in the concept of a breakthrough, such as now is the time to develop 'fan machine' combination.





FC51 C-Tick Certificate FC51 UL&cUL Certificate FC51 VFD CE Certificate FC51 VFD CCC free description FC302 CE



FC302 ISO 9001 Certificate (Chinese, Danish, American factories) FC360 CE Certificate CE Certification

Danfoss VFD certificate

Fan testing report



Certificate of honor



Letters patent



Nord motor certificate



HVLS fan

Second technological revolution ▶

GX HVLS Fan technical team researched and developed domestic first industrial fan from the 2008 to the market, so far has gone through 13 years, we have always adhered to the "down to earth, technology-oriented, focus on quality, brand name service" concept, won the full trust and love of domestic and foreign customers. And in 2018, combined with the global concept of "energy saving, low carbon and environmental protection" at first, we achieved the second technological revolution in the field of ventilation and cooling of industrial fans. With the rapid development of science and technology, high and new technology is constantly emerging, energy saving and environmental awareness are increasing. In the field of power system, China attaches great importance to the research and development of NdFeB permanent magnet motor, and has been included in the national "863" plan. The PMSM permanent magnet synchronous motor technology is first applied to the HVLS large industrial fan field under the guidance of the national strategic policy. The first permanent magnet synchronous motor technology in the world is developed and manufactured, and the "battle axe" series is born in the times. In the process of the second technological revolution of industrial fans, they added the crucial chapter.



WHY CHOOSE GX FAN?

▶ HVLS fans are divided into three systems:

Electrical system, mechanical system, organic integration system

● **Electrical system:** There are two main parts: motor and control frequency converter, after twelve years market precipitation, we have been through so many trials and errors, in the choice of motor and inverter we have chosen a lot of brands. Finally, in the market test, after testing the stability (failure rate), efficiency ratio and other comprehensive factors, the final qualitative nordl motor and danfoss inverter as the main components of the electrical system, the failure rate for many years is almost zero.

● **Mechanical system:** Focus on industrial fans for 12 years, rich technical precipitation. In the past 13 years, we have continuously improved and updated the structural parts and other mechanical parts for seven generations: such as steel beam clamping device, universal joint, double chassis, fan blade structure, internal plug-in (to achieve full integration of point, line, surface).

● **Organic integration system:** Perfect combination of electrical system and mechanical system, organic unity, make the whole fan operation more safe, smooth, smooth, efficient.

▶ Excellent installation team and installation speed timely organic unity

● We have the industry precipitation for a long time and mature perfect installation team: Can meet the installation of various complex installation conditions

● National installation team: Can ensure the timeliness of the installation speed.

▶ Diversified series of small fans

The traditional seventh generation fan, permanent magnet 'Battle axe' series fan, wing Dynamic commercial fan and pole fan can meet the ventilation and cooling needs of different customers and different environments.

▶ Six advantages

- 1、Lead the second technological revolution of industrial fans, with 22% more cost-effective than traditional industrial fans;
- 2、Senior professional team, together with domestic universities, develops permanent magnet synchronous motor fan based on technology and innovation;
- 3、From simplicity to maturity, from products to series, from production to full automation, keep forging ahead and focusing on quality;
- 4、The ultimate cost performance of products and excellent service experience are the cornerstone of our cooperation with customers;
- 5、Mass industry user product usage data, down-to-earth, let small in practice to explore and develop;
- 6、24 hours pre-sales and after-sales brand service, professional protection of customer production needs.

▶ Brand service process

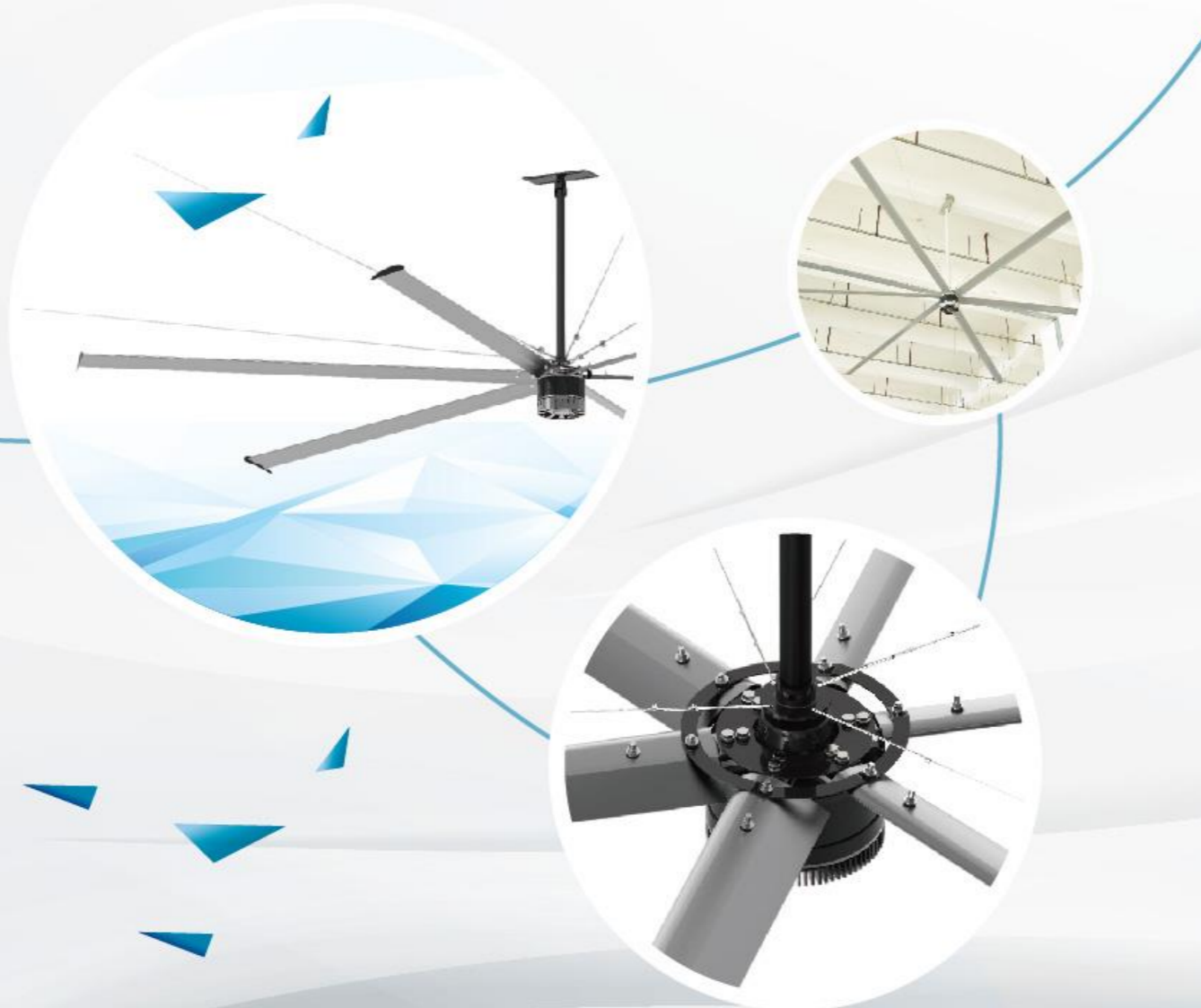
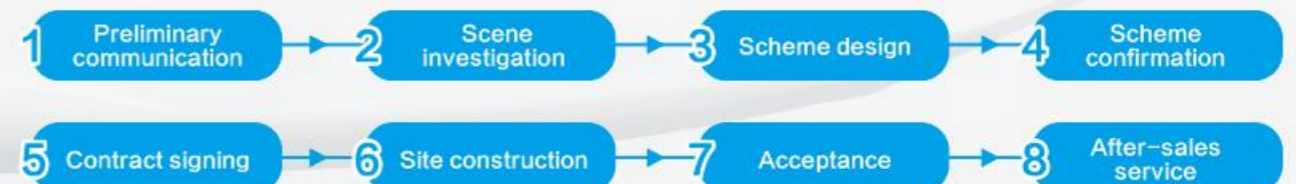



Note: The brief of other part in the fan could refer to traditional fan

BATTLEAXE SERIES

BRIEF INTRODUCTION

GX HVLS Fan latest PMSM Fan, with IP65 grade motor, 91% working efficiency, and the most important is very low temperature inside the motor.

PMSM motor can be designed as an inner rotor and an outer rotor. According to the working mode of the hvls fan, it is advantageous to design the outer rotor because the outer rotor can be directly connected to the main structure of the fan to reduce the moment of inertia. The required starting torque is small, the current is small, so the fan is easy to start and stop. Moreover, the structural connection is simple. From the perspective of motor design, the armature diameter of the outer rotor motor is larger than that of the inner rotor motor. With the same torque design, the total volume of the outer rotor motor can be smaller than that of the inner rotor motor. Under the same performance conditions, it is small in size, light in weight and low in cost. Although the stator winding is inside, it is relatively difficult to dissipate heat, but it is designed according to a reasonable ventilation and heat dissipation structure, and the temperature rise of the motor is controlled at a low level. That design is more reasonable. The advantages and disadvantages of the inner rotor are just the opposite.

GX PMSM MOTOR HAS THE FOLLOWING ADVANTAGES

01

High performance index, large power factor, high efficiency, and maintain high efficiency in the entire operating speed range; the whole machine has a good energy-saving effect.

02

High power density and small size. The structure is simple, there is no gear box, no oil leakage, and maintenance-free.

03

Long lifetime and high reliability;

04

Good speed regulation performance and high precision; stable operation.

05

The moment of inertia is small, the starting torque is large, the current is small, so that the response speed is fast.

06

The noise is small, even super quiet. No impact on environmental noise.

“Battleaxe” permanent magnetic fan model Technology Parameter

Model	Fan diameter (m/ft)	Motor power (kw)	Rotate speed (rpm)	Full load current	Air volume(CMM) m ³ /min	Weight (kg)	Max scope of action(m ²)	Noise (dBA)
BGX-ZF-7E	7.3(24')	1.5	0-54	2.3A	15500	138	1800	≤40
BGX-ZF-6E	6.4(21')	1.5	0-54	1.55A	14500	130	1480	≤40
BGX-ZF-5E	5.5(18')	1.5	0-65	1.35A	13000	121	1050	≤40
BGX-ZF-4E	4.6(15')	1.5	0-65	1.2A	12000	112	850	≤40



⑥ 600W PMSM fan with longest 5.3m fan blades



▶ DRIVING MOTOR

GX HVLS Fan new product 600W PMSM fan, with IP65 grade motor, 83% working efficiency, 70Nm torque, longest fan blades are 5.3m, could totally satisfy lower area ventilation requirement.

▶ HIGH EFFICIENCY FAN BLADE

6-propeller shape, corrected after testing, American Airlines imported (non-imported) high-performance aluminum alloy material: AA6063T6511 (6063-T5); surface anodized PVDF coating (electrostatic spray) treatment;

▶ HUB

American Airlines (AA7075) super-hard aluminum alloy, built by the Japanese company who dedicated to aluminum alloy production for 60 years, high-pressure precision forging type (σ_b reaches 600Mpa), CNC precision machining after dynamic balance test check; ten times force design, 40 years reliability life.

▶ HARDWARE FASTENERS

Germany (DIN933 bolt), class 12.9 (class 8.8); (DIN125A) anti-loose self-locking nut; suspension fasteners use slotted locating pin locknut; drive unit uses Loctite "Lotal" thread to solidify Sexual locking.

▶ THE FREQUENCY OF LEAN CONTROL SYSTEM

(1) Excellent performance, high efficiency and energy saving: HVLS PMSM integrated machine adopts the international leading field-oriented vector control technology, synchronous motor control technology, and static motor parameter self-learning algorithm, which can match various types of PMSM motors. The matching accuracy is high, the output power factor is high, the energy saving effect is good, the motor running current is small, the current fluctuation is small, so that the motor temperature rise is small.

(2) Start and stop the fan stably, low-noise operation: dedicated start-up algorithm for hvls fans with large inertia characteristics, slow start and stop, small start reversal angle, smooth start without jitter, stepless speed regulation, reduce motor wear; stable operation, low motor noise .

(3) Compact structure and high integration: The integrated machine integrates frequency conversion, start-stop, speed regulation, display, and remote control functions. Compact structure, small size, simple disassembly and assembly, and convenient operation.

(4) Advanced technology and strong stability: professional coating, suitable for various processing workshops, workshops, supermarkets, and dust and oily fume environments. High temperature resistant design, when the ambient temperature is high, the equipment runs normally and stably under full load. It is used for the stability and wide voltage design of the harsh power grid, and adapts to the power grid voltage fluctuation range of -15%~+10%; for the harsh EMC environment, the anti-interference ability is strengthened.

(5) Comprehensive functions and high reliability: various protection functions are complete, overcurrent protection, overvoltage protection, overheat protection, short circuit protection, overload protection, etc. It can improve the safe service life of the motor and reduce equipment maintenance.

▶ FIXING DEVICE

The anti-slip groove design and the split pin locknut completely prevent the steel beam clip device from accidentally sliding off, without punching and welding.

● 600W PMSM Ceiling HVLS Fans Parameter

Model	Fan diameter	Motor power	Rotate speed (rpm)	Air quantity (m ³ /min)	Weight (kg)	Largest air coverage (m ²)	Noise (dBA)
BGX-CM-5E	5.3m	600W	0-55	9800	80	900	40
BGX-CM-4E	4.6m	600W	0-60	9000	75	850	40
BGX-CM-3E	3.7m	600W	0-65	8500	70	800	40

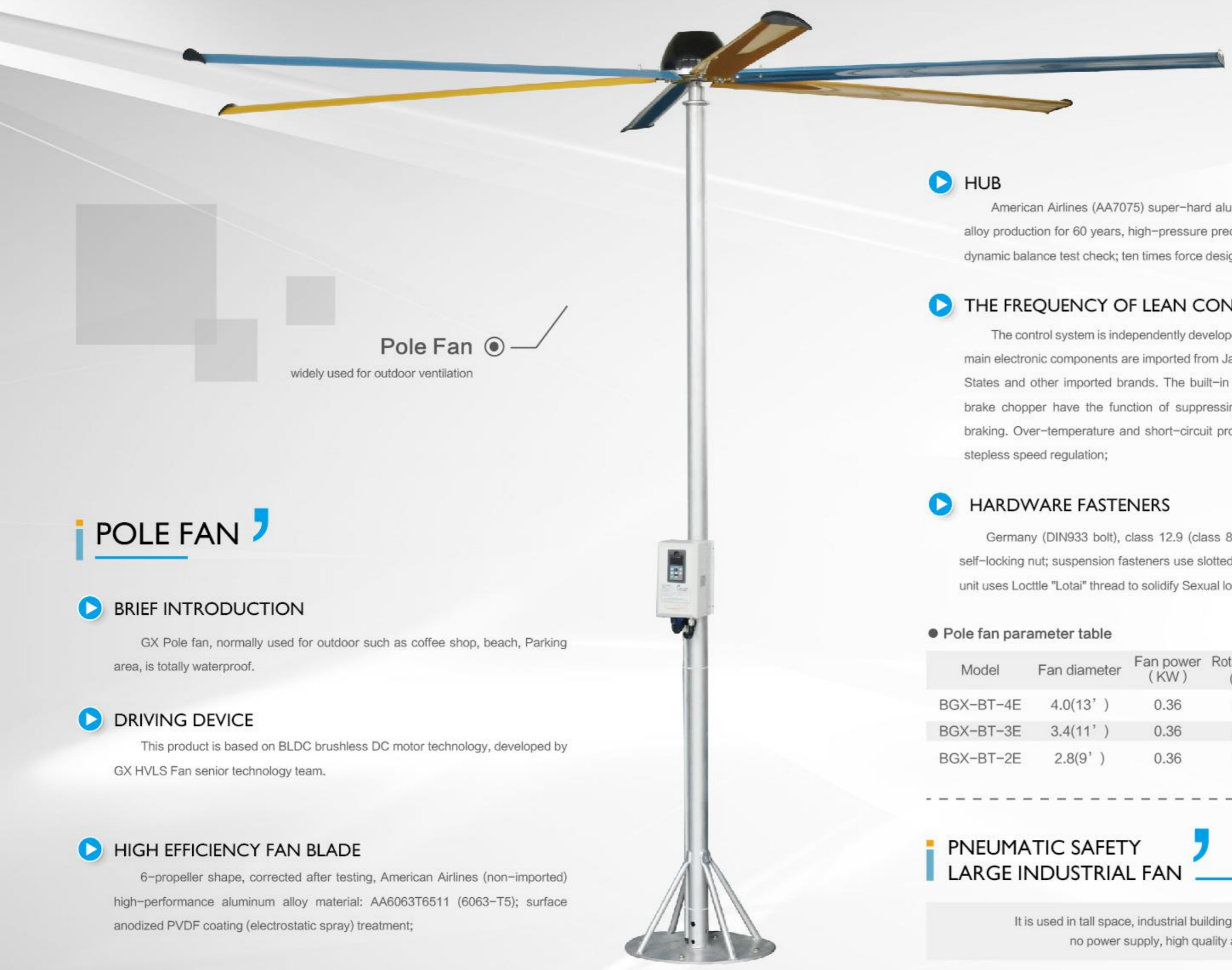

Pole Fan

widely used for outdoor ventilation

POLE FAN

BRIEF INTRODUCTION

GX Pole fan, normally used for outdoor such as coffee shop, beach, Parking area, is totally waterproof.

DRIVING DEVICE

This product is based on BLDC brushless DC motor technology, developed by GX HVLS Fan senior technology team.

HIGH EFFICIENCY FAN BLADE

6-propeller shape, corrected after testing, American Airlines (non-imported) high-performance aluminum alloy material: AA6063T6511 (6063-T5); surface anodized PVDF coating (electrostatic spray) treatment;

HUB

American Airlines (AA7075) super-hard aluminum alloy, built by the Japanese company who dedicated to aluminum alloy production for 60 years, high-pressure precision forging type (σ_b reaches 600Mpa), CNC precision machining after dynamic balance test check; ten times force design, 40 years reliability life;

THE FREQUENCY OF LEAN CONTROL SYSTEM

The control system is independently developed by Jiangsu Gaxiao. The main electronic components are imported from Japan, Germany, the United States and other imported brands. The built-in RF interference filter and brake chopper have the function of suppressing radio interference and braking. Over-temperature and short-circuit protection, etc.; can achieve stepless speed regulation;

HARDWARE FASTENERS

Germany (DIN933 bolt), class 12.9 (class 8.8); (DIN125A) anti-loose self-locking nut; suspension fasteners use slotted locating pin locknut; drive unit uses Loctite "Lotai" thread to solidify Sexual locking;

● Pole fan parameter table

Model	Fan diameter	Fan power (KW)	Rotate speed (rpm)	Wind quantity (m ³ /min)	Weight (kg)	Max scope of action (m ²)	Noise (dBA)
BGX-BT-4E	4.0(13')	0.36	0-70	8200	46	750	40
BGX-BT-3E	3.4(11')	0.36	0-75	5800	42	620	40
BGX-BT-2E	2.8(9')	0.36	0-90	4000	36	520	40

PNEUMATIC SAFETY LARGE INDUSTRIAL FAN

It is used in tall space, industrial building, need explosion proof, high safety, long-term stable use, no power supply, high quality and high price which is a new concept large fan.

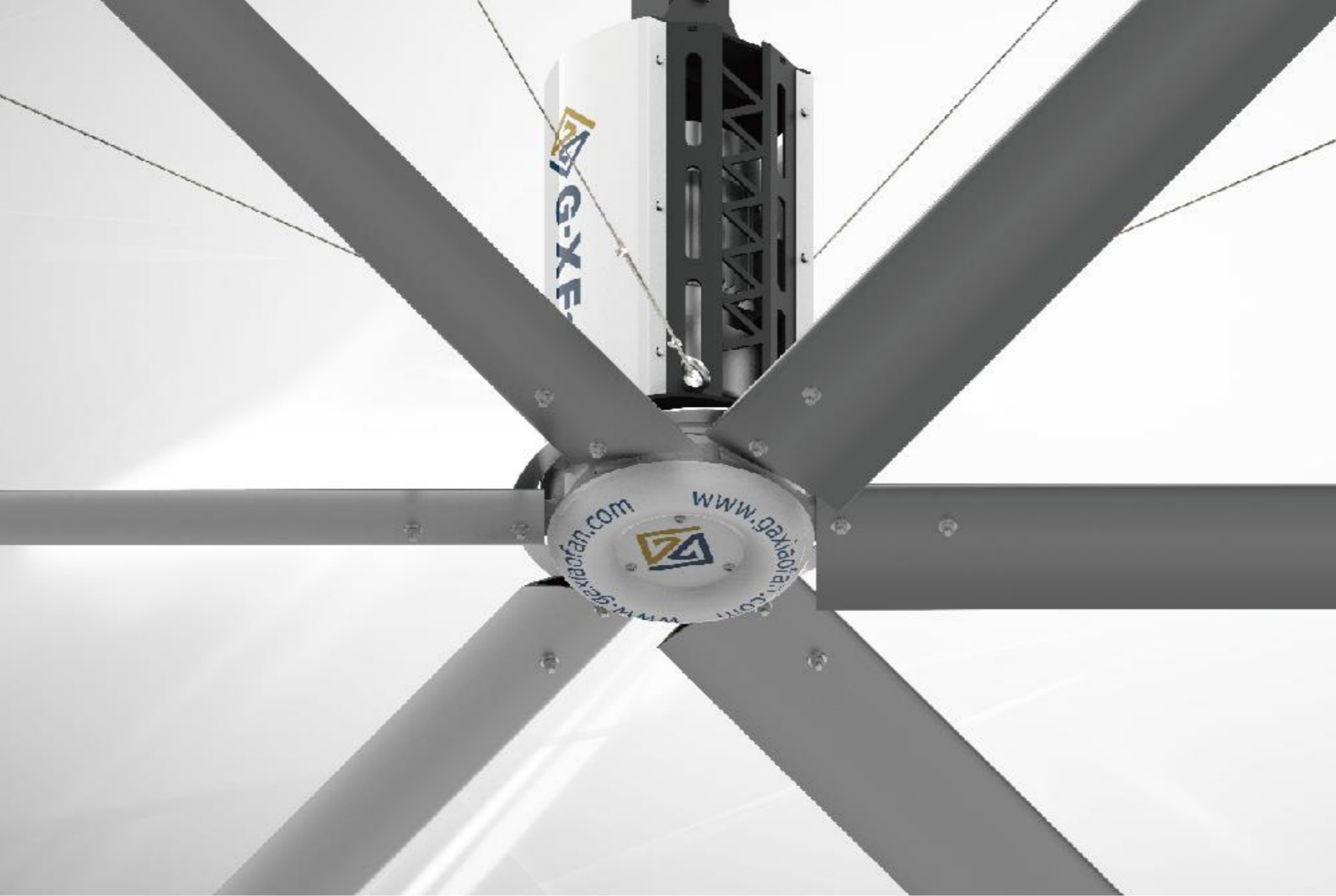

◎ GX 8th Generation HVLS Fan

FEATURES OF TRADITIONAL HVLS FAN

▶ MOTOR REDUCER

German imported ABM motor, 42CrMo output shaft & double tapered bearing; low pressure cast aluminum (special gear arrangement); Dust-proof oil seal (double oil seal design); No breather cap, maintenance-free; Ultra low energy consumption; Super fine grinding.



▶ CONTROL SYSTEM

Our big industrial fan used Denmark 'Danfoss' transducer, the built-in RF interference filter and the brake chopper have the function of restraining radio interference and braking;

It has the functions of earth fault, over and short circuit protection, and so on;

The box is equipped with Schneider three gear switch and infinitely variable speed knob.



▶ HUB

Import American Airlines AA7075 super hard alloy + Japanese precision high pressure forging technology (sigma B 600Mpa) +T6 heat treatment +CNC precision machining + dynamic balance check quality;

Industrial HVLS fan hub is built by Japanese senior corporation, which focuses on precision forging of aluminum alloy for 60 years. The product quality is absolutely guaranteed. Ensure the product's tolerance and dynamic balance are as accurate and reliable as the hub of a car. Hub and motor cover are put together.



Jiangsu Gaxiao Environmental Technology is the prior company in China adopting the combination device of anti falling disk and hub top cover, that is to ensure we are the outstanding factory who combines upper, lower chassis with fixed fan wing to solve the safety problem (at present, the other manufacturers mostly use the single chassis so as to reduce cost). At the same time, this reduces the weight of the whole big industrial ceiling fan, and improves the efficiency of the motor to realize perfect combination.

The anti falling disk adopts the lower part closely connecting with hub. This improves the current market situation of connecting anti falling disk with frame, which exists a certain risk of operating.



- ◆ 6 propeller shape, import American Airlines high performance aluminum alloy material:AA6063T6511
——Long-life warranty;
- ◆ Shape design developed by Profili V2 airfoil simulation analysis software
——To ensure the maximum comfort of the fan effect

▶ FAN BLADE

The size of the industrial ceiling fan blade is amplified by 20% of all the current fan sizes, which will increase the air volume. It also proves that the weight of the whole machine is reduced and the efficiency of the motor is improved.

The fan blade adopts the internal steel cable, the stiffened reinforcement combination, the fan blade and the fixed point line and surface safety method. (at present, two bolts are used in the fixed way in China, and it is easier to aggravate the damage of the fan blade fatigue point).

● High Volume Low Speed Industrial HVLS Fans Technical Parameters

Model	Fan diameter (m) ft	Motor power (kw) hp	Rotate speed (rpm)	Full load current (A) 380v	Air volume (CMM) m ³ /min	Weight (kg)	Max scope of action (m ²) Sqm	Noise (dBA)
BGX-TD-7E	7.3(24')	1.5/2.0	0-53	2.95	13800	125	1800	43
BGX-TD-6E	6.4(21')	1.5/2.0	0-53	2.72	12800	113	1400	43
BGX-TD-5E	5.5(18')	1.5/2.0	0-65	2.75	12000	108	1050	43
BGX-TD-4E	4.6(15')	1.5/2.0	0-65	2.85	11500	102	850	43
BGX-TD-3E	3.7(12')	1.5/2.0	0-70	2.72	10500	90	680	43

▶ OTHER SAFETY ACCESSORIES

Frame
High strength structure Z type 5mm steel plate, laser cutting, robot double-sided welding, surface PVDF fluorocarbon baking paint treatment, more reliable and durable.

Steel Anti Shedding Protection Disc
The new Q345B Steel Anti shedding protection disc is connected with the hub, which is more convenient and effective, avoiding the potential safety problems associated with the rack connection.

Anti Slip Slot Design
The exclusive anti slip slot design and the opening pin nut prevent the steel bar clamping device from slipping and falling off without any punching and welding.

40Gr alloy cast steel universal joint can reduce torque transmission to buildings, like human joints;

All fasteners are equipped with anti-loose self-locking nut and toothed anti-fall pad

Install the mounting bracket and the steel wire safety strap between steel beam to prevent accidental falling off;

(Installed in the middle of the hub) The mold sleeve design prevents the rotating chassis from accidentally slipping

Wire traction cable prevents the fan from being affected by external forces;

Each fan blade is equipped with an L-shaped safety link buckle to prevent the blades from falling off individually;

Fan hub unit is provided with anti-drop structure

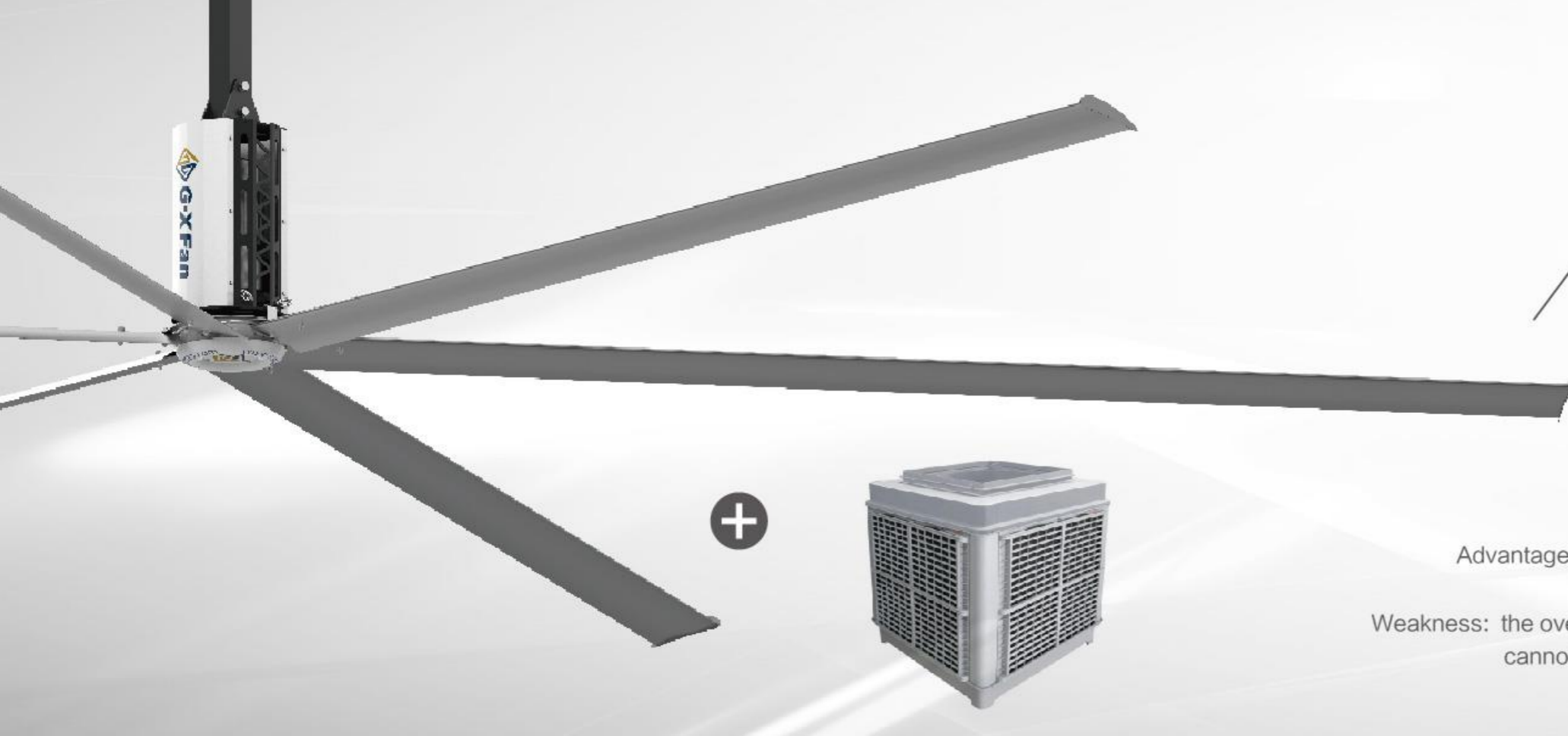

Fan Machine combination

New concept of global low carbon ventilation&cooling

HVLS fan
 Advantages: ventilation and sensory cooling
 Weakness: the overall environment cannot be cooled down

Fan Machine Combination

Steam air cooler
 Advantages: overall cooling
 Weakness: more unsightly pipeline, higher cost

FAN MACHINE COMBINATION

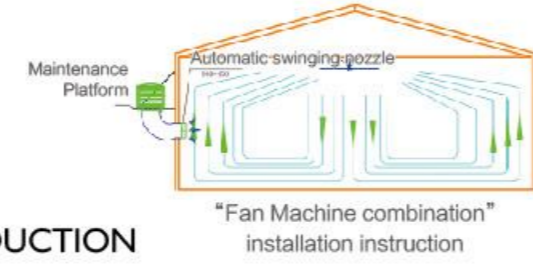

FAN MACHINE COMBINATION BRIEF INTRODUCTION

The "Fan Machine combination" scheme refers to the combination design of the large industrial fan (super ceiling fan) and steam air cooler (commonly known as environmental protection air conditioner) which have obvious advantages in the asia-pacific region. After professional calculation, combining with the actual needs of the customer's work site, it scientifically carries out the combined design for the customer's high and large space environment. After the implementation of the plan, the two types of products will complement each other's advantages. While giving full play to their effects, they will make up for each other's shortcomings in efficiency, and finally show very good comprehensive effect and application value.

FAN MACHINE COMBINATION SOLVE THE DIFFICULTIES

No steam air cooler, the fan to cool senses well, but not to cope with environmental temperature, without big fan, using only air cooling machine and a large number of supply air duct must be set hanging under the roof, in room beautiful sex influence space and construction safety, increase the cost of investment, only the fan unit close to balance, ventilation cooling, ventilation, saving, beautiful, safe goal implementation has a great significance to the improvement of the indoor air and very good economic and practical value.

THE VALUE OF FAN MACHINE COMBINATION

- 1、 Large air volume and super silent, forming a natural three-dimensional breeze system in large and high indoor space, with no dead space for ventilation and cooling, and wide coverage;
- 2、 Not only can the staff realize the cooling of human senses, but also the overall cooling of the environment. With a certain wind speed, the human body feels comfortable. For places with requirements for environmental humidity, it can also keep indoor air dry and avoid corrosion and deterioration of equipment and products.
- 3、 Create a fresh air environment, which can achieve the goal of all-round environmental improvement that cannot be achieved by using a large fan alone or a steam air cooler alone;

- 4. The steam air cooler and fan can use one set of systems alone or even one or several devices in one set of systems alone according to seasonal needs, so as to meet the actual needs of customers to the maximum extent and reduce operating costs;
- 5. Ventilation, cooling, safety, saving and aesthetics, all the objectives concerned by customers are realized at one time;
- 6. In a sense, it can replace traditional air conditioning. If used in combination with air conditioning, energy saving of air conditioning can be achieved.

GX "FAN MACHINE COMBINATION" PRACTICAL APPLICATION

A. When both systems are switched on at the same time

During normal production and use in high temperature weather in summer, two sets of systems are opened and operated at the same time. For example, 40 coolers installed on the outdoor wall continuously deliver fresh air after filtering and cooling. By outdoor guide duct into the window with swing type air supply way to the workshop internal transport per hour up to 920000 m³ fresh wind cold, along with slow rotation eight big fans hanging in the high place, with the largest 105600 m³ per minute volume air circulation, extensive, three-dimensional drive, make the cold fresh air from steam air cooler spread effectively, push evenly throughout the workshop, realize the workers and the environment cooling and ventilation. The design not only ensures good ventilation and cooling effect, but also takes into account the security of building roof bearing and the aesthetics of space. It saves investment and daily running cost, and can produce good economic and social value. The simulation is as follows:

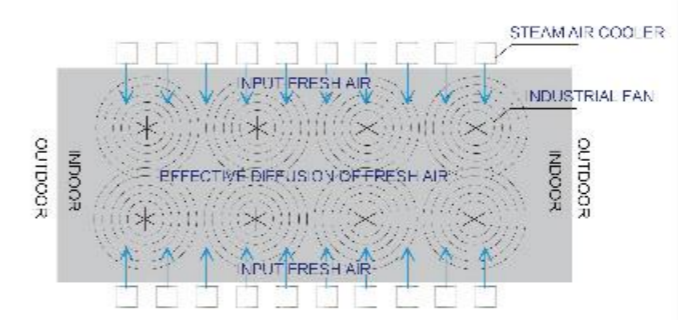

B. When the two systems are turned on separately

Another bright spot is the solution: according to the user's actual need (the user not full production, or is not very hot in the spring and autumn season, but some workshop hot), the above designed two sets of cooling system can be used alone, or even can be used in a separate one set of system, also can realize control alone, single use, to the greatest extent to meet the user in different seasons, different period of the practical need of production, support to promote enterprise good energy saving target.

INSTALLATION CONDITION

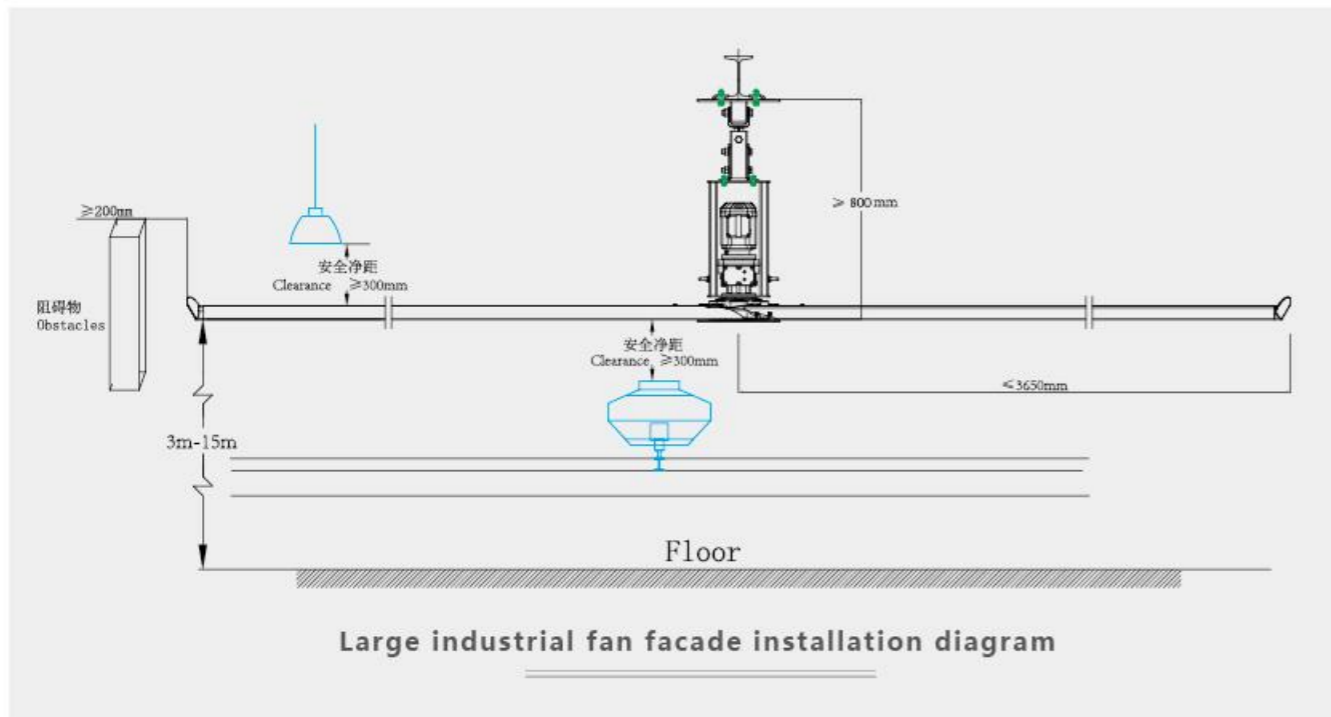

A、What kind of building is suitable for installing large industrial fans?

As long as the height of the plant is above 5.5 meters, no matter the structure of the plant is steel structure, concrete structure, spherical grid structure, or complex structure, there are no special requirements for installation places, such as factory, warehouse, commercial center, train station, car station, exhibition hall, and animal farm. There is no driving inside the workshop can all install, both 220V and 380V can be installed.

B、Basic requirements for installation

- 1) The minimum safe and effective installation space of the fan is more than 1.2 meters.
- 2) Choose a safe carrying beam to install it, otherwise our company can install it according to the site transformation.
- 3) The special installation site can be installed according to the site transformation.

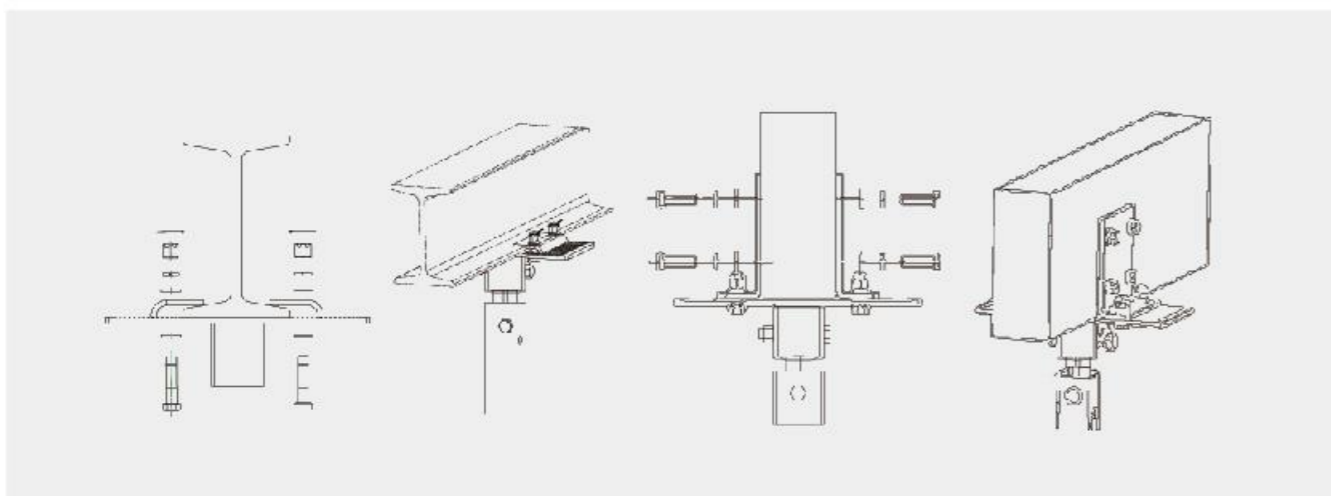

INSTALLATION DETAILS

GX HVLS Fan part details, pay more attention to product material

Domestic first company who combines fan blades, anti sling cables, and the whole fan to protect the steel cables, three to one.

1、Security measures

- 1) Fan leaf L shape safety ring: Reconnect all fan blades two-two together into a whole structure.
- 2) Safety ring: When accident happens, it plays a protective role and prevents any part from slipping.
- 3) Fasteners: All fasteners are as high as 8.8 grade high strength industrial bolts, and the actual stress is more than 10 times.
- 4) Wire traction: The stress intensity of each wire rope can reach 1000KG, and multiple protection points are installed at each connection point.
- 5) The frequency conversion control system is automatically stopped by accident.

2、Safety device

- 1) Fan and building structure are connected through universal joints to reduce vibration and displacement to the building structure.
- 2) The fan hub set up anti-falling structure.
- 3) Install bracket and steel beam and install steel wire safety rope to prevent accidental fall off.
- 4) Each fan blade is equipped with L type safety link button to prevent individual leaves fall off.
- 5) The design of the die sleeve prevents accidental slip of the rotating chassis.
- 6) All fasteners are all installing anti-loosening self-locking nuts and tooth shaped anti falling pads.
- 7) Steel wire traction cables prevent fans from shaking due to external forces.
- 8) The whole fan passes the European CE safety authentication and examination, the enterprise passes CQC, ISO9001, SCS authentication.
- 9) All products are covered by Pacific product liability insurance and public liability insurance. All employees are liable for liability insurance.

3、Installers necessity

- 1) All the workers in high place hold the high duty certificate;
- 2) All the workers in high place are equipped with safety helmets, seat belts, special hoisting tools, and professional installation tools for installation.
- 3) All employees are trained after third levels of training and customer safety training.





FUNCTION INTRODUCTION

PERSONNEL COOLING

BGX series of large fans generate the natural breeze blowing on the human body, promoting the evaporation of sweat to take away heat, and cooling the human body, bringing cooling feelings. Usually, this kind of cool feeling can reach 5-8 °C. BGX series of large fans blowing the three-dimensional natural wind is more comfortable because:

On the one hand, to the human body all-dimensional blowing to make the human body evaporation area to the maximum.

On the other hand, the reason is that human beings have accumulated a kind experience of natural wind in the nature. Once the natural breeze with wind speed changes, the human body naturally feels extremely comfortable and cool.

How can cool the body to reach 5-8 °C

The BGX series of large fans speed up the flow of the air, thus quickening the evaporation of the sweat, and taking away the heat from the body during the evaporation of the sweat, so we will feel cool.

The impact of specific wind speed on human feelings is discussed. Corresponding to different temperature and speed, the difference curve of human feelings.

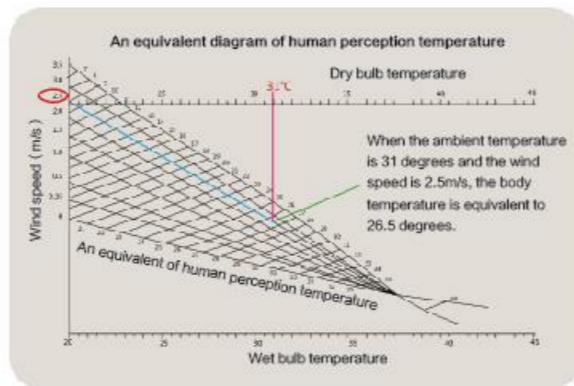

NATURAL WIND

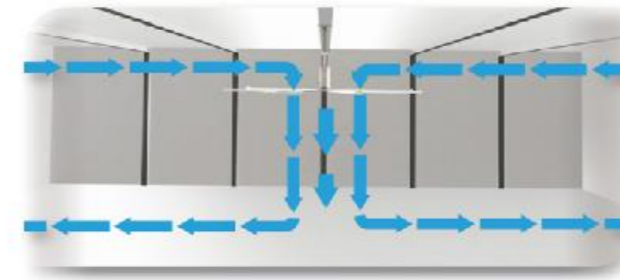

In the large and wide closed space, the ventilation scheme is greatly restricted. The roof negative pressure fan does not work at all corners and ground air, and this is precisely the position of personnel and equipment. With the BGX series of large fan schemes, the problem is solved. BGX series of large fans can effectively enhance the orderly movement of air flow in the space. It will promote the mixing of air in the whole space and cooperate with the roof fan to improve the effect of air quality. Get a healthy, comfortable and safe working environment.

DEHUMIDIFICATION

BGX series of large fans can solve this problem: the advantage lies in being direct and effective. It promotes the mixing of air and air in the whole space. It can make the smoke and tidal gas with difficult smell to be well dispersed and absorbed, so as to improve the indoor air quality and obtain a healthy, dry and safe working environment. It can also avoid the noise generated by other ventilation schemes and the decay caused by moisture.



Experimental data of using large scale fan to solve excessive local humidity.

	Humidity range					
Normal condition	30%	40%	50%	60%	70%	80%
Open fan	27%	35%	43%	50%	58%	65%
Reduce relative humidity	3%	5%	7%	10%	12%	15%
Percentage of decrease in humidity	10.00%	12.50%	14.00%	16.67%	17.14%	18.75%

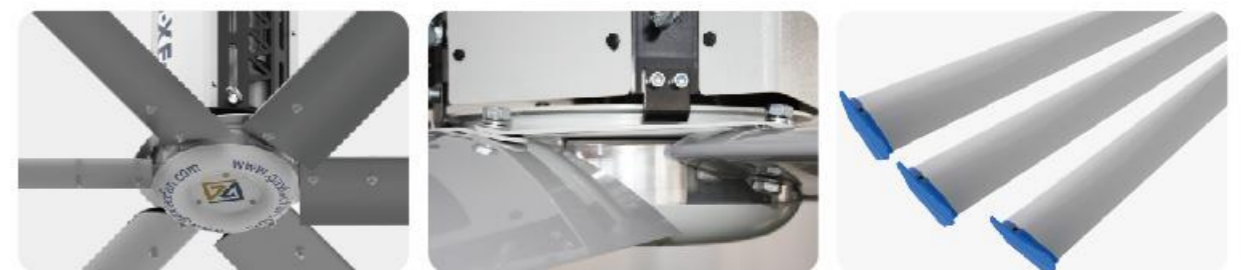



▶ PRODUCT FEATURES AND TECHNOLOGY

◆ Compare with small fan project effect

Small-scale fan scheme

Many logistics storage space adopts the traditional small high speed fan scheme. Besides the health problems such as fan disease because of the long-term direct blowing of the fan, the biggest problem in the logistics industry is that the field workers are also moving at any time. Because the small fan coverage is small, it can only cover the 20%-30% site area, in fact, can not fundamentally solve the problem of ventilation and cooling in the logistics industry.

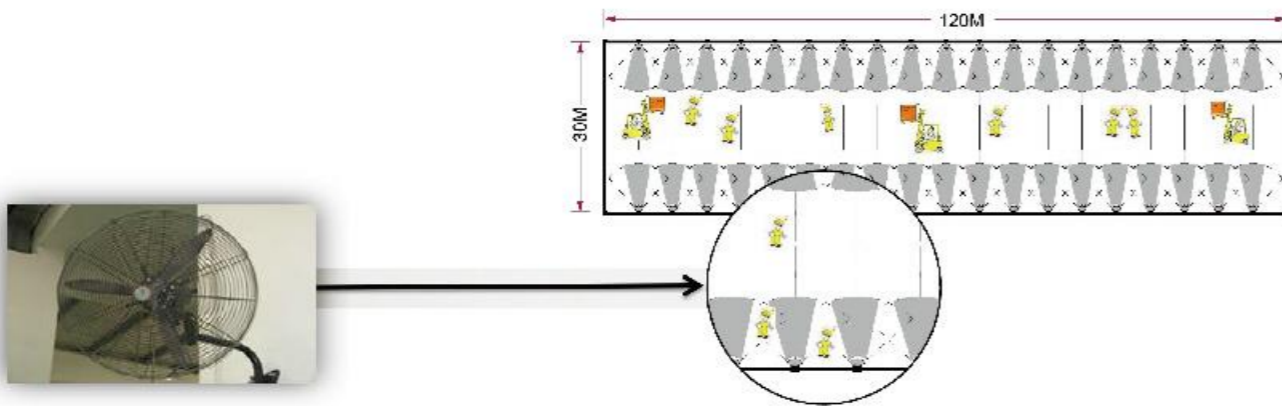

◆ Compare with small fan project effect

BGX series large-scale fan scheme

BGX series of large fans are used to cover the whole area without leaving dead ends. The large air volume and covering area will bring comfortable natural breeze, make the working environment change immediately, not only can cool the body directly, but also bring the whole field ventilation and the excellent dehumidification effect!

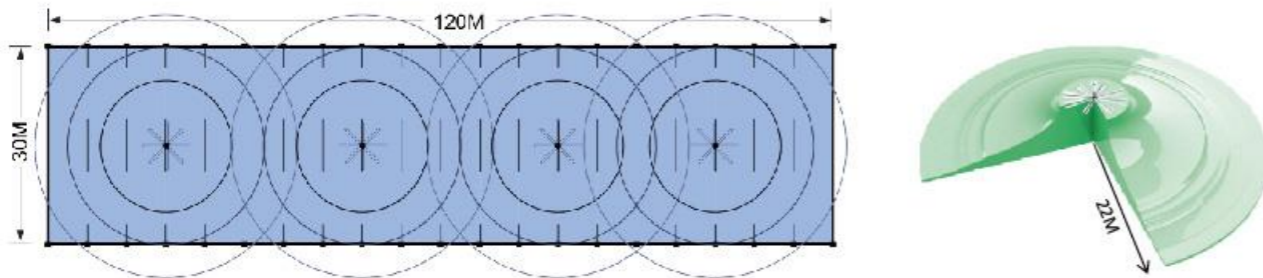

◆ Compare saving-energy with small fan

★ Compare with small fan:

A large BGX fan with a diameter of 7.3M covers an area equal to the coverage area of 50 units 0.75M small fans. For example, in a 9000 square meter factory building, we hope to achieve the full coverage effect. We need about 300 units small fans, while the BGX series large fans only need 6 units. According to the use of 4 years, 8 months a year, 10 hours a day, about 10000 hours, BGX series of large fan power consumption 90000KW.h, small fan 1080000KW.h, energy saving 990000KW.h, energy saving 92%!

Diameter (m)	Covering area (m ²)	Wind quantity (m ³ /min)	Fan quantity (set)	Power (KW)	Operating time (h)	Electric consumption (degree)	Total cost (Yuan)	Saving (Yuan)	Using lifetime (year)
7.3	1500	13500	6	1.5	10000	90000	90000	¥ 990,000	10
0.75	30	300	300	0.36	10000	1080000	1080000		2

Application attribute comparison table:

Application attribute	Large fan	Small strong fan
Free maintenance	✓	✗
Comfort	✓	✗
Easy operating	✓	✗
Easy manager	✓	✗

◆ Huge coverage area

When our customers feel the huge coverage of the super large fan, they all have the same admiration: 'this fan is so low, the power is so small, why can it cover such a large area?' The BGX series of large fans can cover such a large area, depending on the unique streamlined design of the fan blade, which minimized the resistance and converted the maximum energy efficiency into the kinetic energy of the air. In addition, the air flow structure of the fan is different from that of the ordinary small fan. The small fan can only cover the range of the fan diameter, and the large BGX fan first puts the air flow vertically to the ground, then forms a 1-3 meter high air flow layer on the ground, thus forming a super large coverage area not only limited to the BGX series large fan. In an open space, a fan can even cover 1400 square meters of super large area.

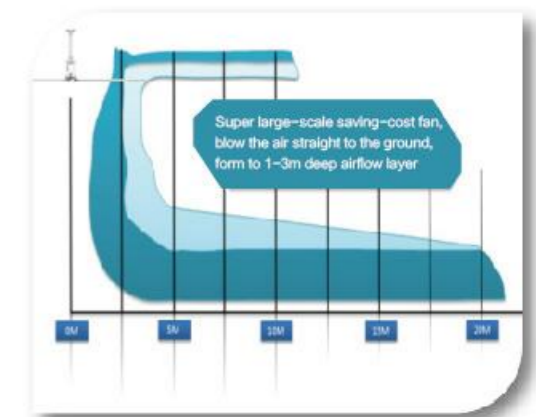



APPLICATION CASE



COMPANY ▶ Service

